

## Swamperella Stage Plot: 2009

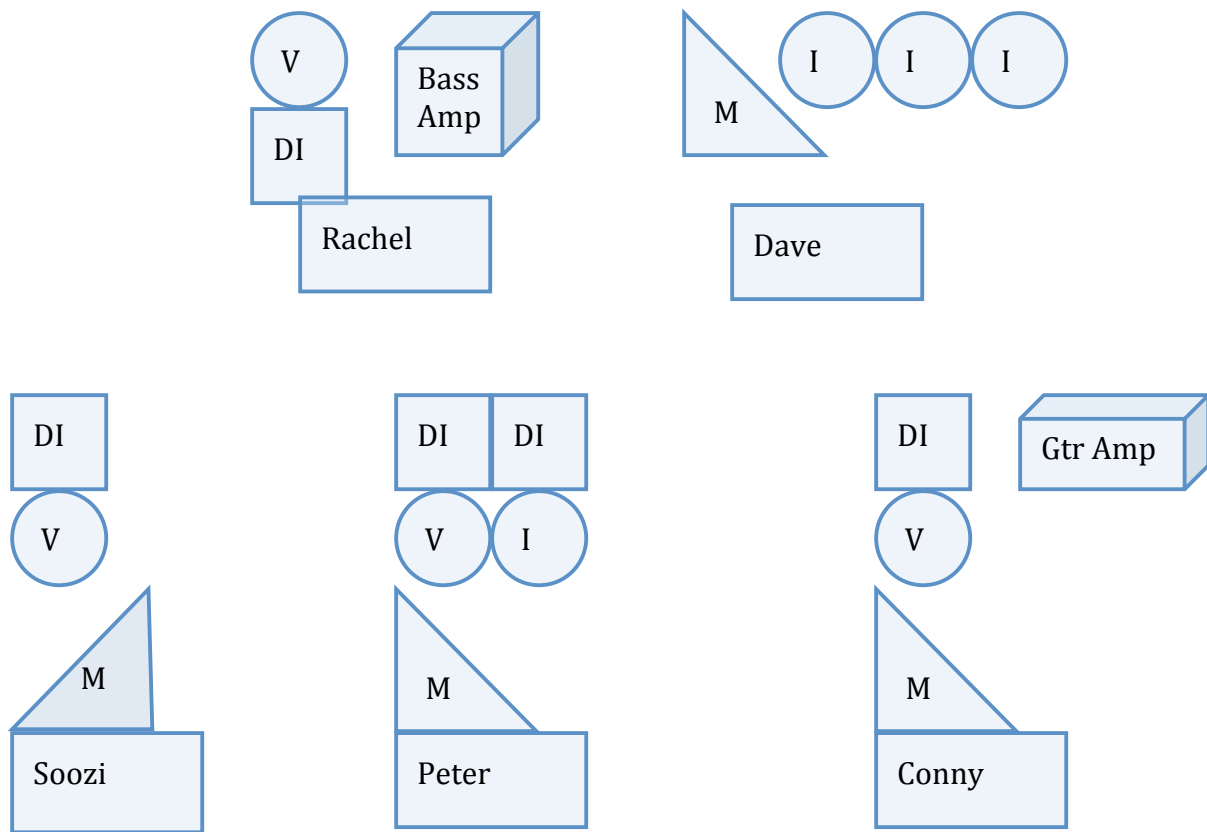

### AUDIENCE

DI = Direct Box V = Vocal Mic I = Instrumental Mic M = Monitor

**Soozi:** DI for her fiddles  
vocal mic

**Peter:** two DIs for fiddle and accordion  
vocal mic  
instrumental mic (for chord side of accordion, stand not required)

**David:** one instrument mic for snare drum  
one bass drum mic  
one instrument mic for triangle. Will also be used for washboard by Soozie

**Rachel:** bass DI or XLR  
vocal mic

**Conny:** DI for Acoustic Guitar  
vocal mic

Everyone except David requires AC

Monitors: if there are a limited number of mixes, Soozie should have her own mix, and the rest of the band can be on another mix.  
Soozie needs the lower half part of a mic stand to mount her personal monitor